

A- GENERAL DIAGRAM

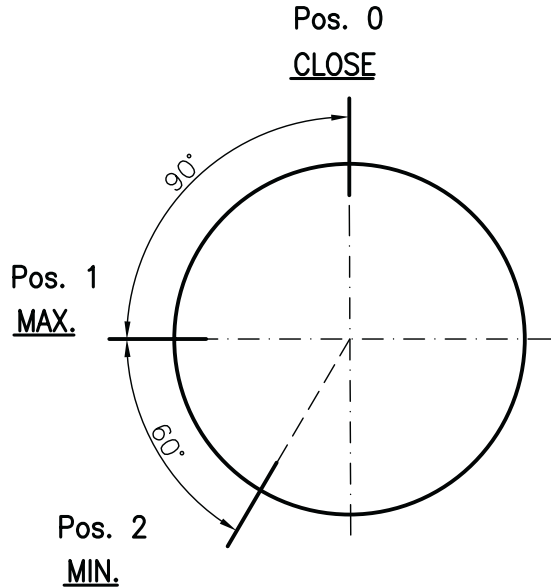

B- WITHOUT PILOT OUTLET

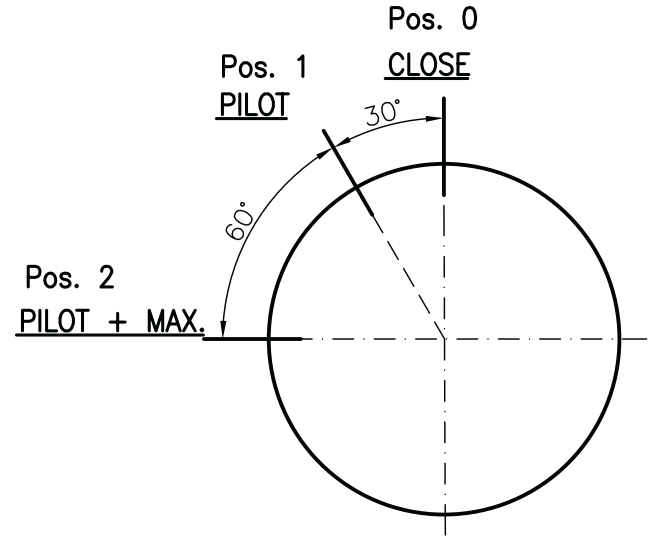

C- ONLY PILOT AND MAXI FLOW

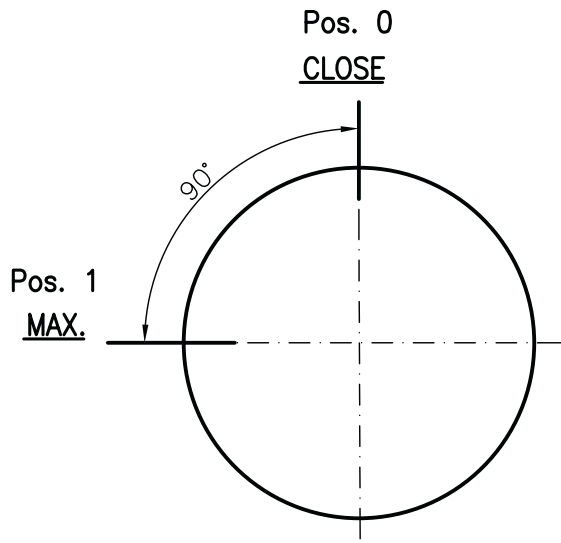

D- ONLY MAXI FLOW

TURN DIAGRAM OPTIONS